

# PRODUCT SPECIFICATION

## 产品规格书

**Date 日期:**

20251103

**Project Name 项目名:**

CMB01010191

**Manufacturer****生产制造商**

CM Batteries Co.,Ltd

**Customer ID****客户编码:**

SI097

page: 1

<b>Project Code/项目代码</b>	CMB01010191
<b>Version NO./ 版本号</b>	A0
<b>Product Name/ 产品名称</b>	/
<b>Model/ 型号</b>	3.6V 2AH

<b>Drafted By/ Date 拟定/日期</b>	20251103
<b>Checked By/ Date 审核/日期</b>	20251103
<b>Approval By/ Date 审批/日期</b>	20251103

<b>Customer Approval/ 客户确认</b>	<b>Checked By/Date by 审核/日期</b>	<b>Approval By/ Date 审批/日期</b>
<b>Company Seal/公章</b>		

**Tel:** +86 158 1732 3917**Email:** cherry@cmbatteries.com**CMB Headquarters:**

Rm.1216 ,

Baoshan Times Bldg,

Minqiang Community,

Minzhi St.,Longhua Dist.,

Shenzhen

GuangdongChina

**CMB Facotry:**

Rm.702,7/F,4 BLDG,NO.160,

Tianxin Luyuan Rd.,

Keyuan City,Tangxia Town,

Dongguan,

Guangdong,China



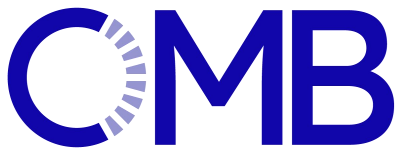

# PRODUCT SPECIFICATION

## 产品规格书

### TABLE OF CONTENTS 目录

1. Amendment Records 版本变更记录.....	2
2. TABLE OF CONTENTS 目录 .....	3
1. Standard 标准.....	4
2. Production description 产品描述 .....	4
3. Scope 范围.....	5
4. Product parameters 产品参数.....	5
5. Battery Pack and BMS Information 电池组和 BMS 信息.....	6
6. Main Components List for BMS 主要元器件清单.....	7
7. BMS Layout and Diagram BMS 布局和示意图.....	8
8. Material Sheet 材料表.....	9
9. Battery Pack Reliability Test 电池组可靠性测试.....	9
9.1. Testing Condition 测试条件.....	9
9.2. Requirements for measuring instruments and equipment 测量仪器设备要求.....	10
9.3. Specifications for testing electrical performance parameters 电气性能参数测试规范.....	10
9.3.1.Charge Test 充电测试 .....	11
9.3.2. Discharge Test 放电试验 .....	11
9.3.3. Rated Capacity 额定容量 .....	12
9.3.4.Charge Retention 电荷保持能力 .....	12
9.3.5. Internal Impedance 内阻.....	12
9.3.6. Life Cycle Test 循环寿命测试.....	13
9.4. Environmental Performance 环境性能.....	13
9.4.1. High Temperature Performance 高温性能.....	13
9.4.2. Low Temperature Performance 低温性能.....	14
9.4.3. Constant Temperature and Humidity Performance 恒温恒湿性能.....	14
9.4.4. Heat Test 热冲击.....	15
9.4.5.Vibration Test 振动测试.....	15
9.5. Battery Safety Protection Performance Test Range 电池安全保护性能测试范围.....	15
9.5.1.Overcharge Protection 过度充电保护.....	15
9.5.2. Over discharge Test 过度放电测试.....	16
9.5.3. External Short-circuit Test 外部短路测试.....	16
10. Transportation, Storage 运输、存储.....	16
10.1. Transportation 运输.....	16
10.2. Storage 存储.....	16
11. Handling Instructions 操作说明.....	17
12. Amendment of this Specification 产品规格书的修订.....	18

#### Date 日期:

20251103

#### Project Name 项目名:

CMB01010191

#### Manufacturer

##### 生产制造商

CM Batteries Co.,Ltd

#### Customer ID

##### 客户编码:

SI097

page: 3



Tel: +86 158 1732 3917

Email:cherry@cmbatteries.com

#### CMB Headquarters:

Rm.1216,  
Baoshan Times Bldg,  
Minqiang Community,  
Minzhi St.,Longhua Dist.,  
Shenzhen  
GuangdongChina

#### CMB Facotry:

Rm.702,7/F,4 BLDG,NO.160,  
Tianxin Luyuan Rd.,  
Keyuan City,Tangxia Town,  
Dongguan,  
Guangdong,China

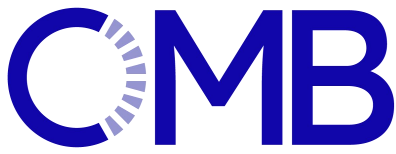

# PRODUCT SPECIFICATION

## 产品规格书

**Date 日期:**

20251103

**Project Name 项目名:**

CMB01010191

**Manufacturer****生产制造商**

CM Batteries Co.,Ltd

**Customer ID****客户编码:**

SI097

page: 4

**Product Summary 产品概要****1. Standard 依据标准**

This product complies with National Standard GB 31241-2022 《Lithium-ion Battery General Specifications》 of PRC.

本产品依据标准：中华人民共和国国家标准 GB 31241-2022 《便携式电子产品用锂离子电池和电池组安全要求》。

**2. Production description 产品描述**

a) Cell 电芯: INR18650 2000mAh

b) Structure Drawing 电池结构图:

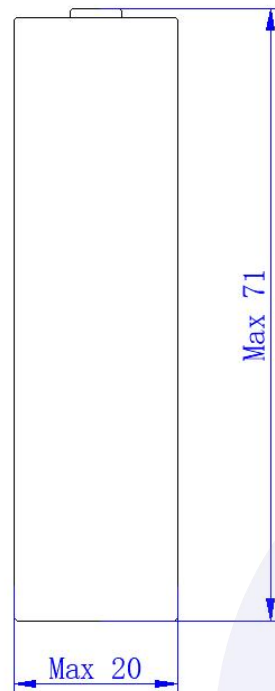

**Tel:** +86 158 1732 3917

**Email:** cherry@cmbatteries.com

**CMB Headquarters:**

Rm.1216 ,  
Baoshan Times Bldg,  
Minqiang Community,  
Minzhi St.,Longhua Dist,  
Shenzhen  
GuangdongChina

**CMB Facotry:**

Rm.702,7/F,4 BLDG,NO.160,  
Tianxin Luyuan Rd.,  
Keyuan City,Tangxia Town,  
Dongguan,  
Guangdong,China



# PRODUCT SPECIFICATION

## 产品规格书

### Date 日期:

20251103

### Project Name 项目名:

CMB01010191

### Manufacturer

#### 生产制造商

CM Batteries Co.,Ltd

### Customer ID

#### 客户编码:

SI097

page: 5



Tel: +86 158 1732 3917

Email: cherry@cmbatteries.com

### CMB Headquarters:

Rm.1216,  
Baoshan Times Bldg,  
Minqiang Community,  
Minzhi St.,Longhua Dist.,  
Shenzhen  
GuangdongChina

### CMB Factory:

Rm.702,7/F,4 BLDG,NO.160,  
Tianxin Luyuan Rd.,  
Keyuan City,Tangxia Town,  
Dongguan,  
Guangdong,China

### 3. Scope 范围

This specification applies to the technical requirements, test items, testing rules, safety warnings, packaging, transportation and storage of lithium-ion battery packs produced by CM BATTERIES.

本规格书适用于 CM BATTERIES CO.,Ltd 生产的锂离子电池组的技术要求、测试项目、测试规则。

### 4. Product parameters 产品参数

ONO. 序号	Item 项目	Parameter 参数	Remark 备注
1	Nominal Voltage 标称电压	3.6V	3.6V/cell
2	Nominal Capacity 标称容量	2Ah	@0.2C
3	Minimum Capacity 最小容量	1.9Ah	
4	Shipment Voltage 装运电压	/	
5	Initial Internal Impedance 初始内阻	≤100mΩ	AC 1KHZ
6	Standard Charge Voltage 标准充电电压	4.2V	4.2V/cell
7	Standard Charge Current 标准充电电流	0.4A	@0.2C
8	Max. Charge Current 最大充电电流	2A	
9	Standard Discharge Current 标准放电电流	0.4A	@0.2C
10	Max. Discharge Current 最大放电电流	3A	
11	Burst Discharge Current 突发放电电流	8±2A	≤10ms
12	Discharge Cut-off Voltage 放电截止电压	2.4V	2.4V/cell
13	Cycle life 循环寿命	≥350cycles	Retention: ≥70%
14	Charge Temperature 充电温度	-20°C~0°C (0.2A) 0°C~+60°C (2A)	Max Charge
15	Discharge Temperature 放电温度	-40°C~+85°C	Standard Discharge
16	Storage Temperature 储存温度	-20°C~+45°C	≤3 months
		-20°C~ +25°C	≤1 year
17	Weight 重量	About 0.05	kg
18	Special Request 特殊技术要求	/	/

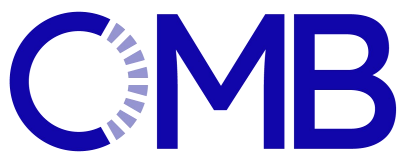

# PRODUCT SPECIFICATION

## 产品规格书

**Date 日期:**

20251103

**Project Name 项目名:**

CMB01010191

**Manufacturer****生产制造商**

CM Batteries Co.,Ltd

**Customer ID****客户编码:**

SI097

page: 6

**Tel:** +86 158 1732 3917**Email:** cherry@cmbatteries.com**CMB Headquarters:**

Rm.1216,

Baoshan Times Bldg,

Minqiang Community,

Minzhi St.,Longhua Dist.,

Shenzhen

GuangdongChina

**CMB Facotry:**

Rm.702,7/F,4 BLDG,NO.160,

Tianxin Luyuan Rd.,

Keyuan City,Tangxia Town,

Dongguan,

Guangdong,China

**5. Electrical Characteristics for BMS BMS 的电气参数**

No	Item	Condition	Specification
1	电压/ Voltage	充电电压/Charge voltage	4.2V
2	过充电 Overcharge	保护电压/Detection voltage	4.30V±50mV
3		恢复电压/ Release voltage	4.15V±50mV
4		保护延迟时间/ Detection delay time	80ms-200ms
5	过放电 Over discharge	保护电压/Detection voltage	2.4V±0.1V
6		恢复电压/ Release voltage	3.0V±0.1V
7		保护延迟时间/ Detection delay time	40ms-100ms
8	放电过流 Over discharge current	放电过流保护电流/Over current	8±2A
9		放电过流保护延时/delay time	10ms-20ms
10	短路保护	短路保护延时/ Short detection delay time	50us (MAX)
11	自耗电 Normal current consumption	工作状态自耗电 Normal current consumption of PCM	6μA (MAX)
12	建议工作条件 Suggest working conditions	建议最大持续充/放电电流 max continuous charge/discharge current	充电: 2A 放电: 3A
13	内阻/IR resistance	PCM 内阻/ IR of PCM	45-65mΩ



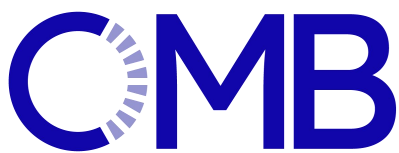

# PRODUCT SPECIFICATION

## 产品规格书

**Date 日期:**

20251103

**Project Name 项目名:**

CMB01010191

**Manufacturer**

**生产制造商**

CM Batteries Co.,Ltd

**Customer ID**

**客户编码:**

SI097

page: 7

**6. Main Components List for BMS 主要元器件清单**

NO	描述 Description	器件编号 Location	规格/part No. Specification	单位 unit	数量 Qty	备注 Remark
1	IC	U1	DW01+ S0T-23-6	PCS	1	
2	MOS	U2	8205A S0T-23-8	PCS	2	



**Tel:** +86 158 1732 3917

**Email:** cherry@cmbatteries.com

**CMB Headquarters:**

Rm.1216 ,  
Baoshan Times Bldg,  
Minqiang Community,  
Minzhi St.,Longhua Dist.,  
Shenzhen  
GuangdongChina

**CMB Facotry:**

Rm.702,7/F,4 BLDG,NO.160,  
Tianxin Luyuan Rd.,  
Keyuan City,Tangxia Town,  
Dongguan,  
Guangdong,China



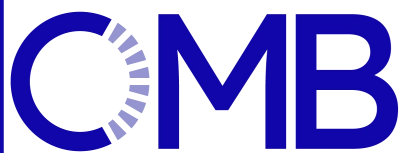

# PRODUCT SPECIFICATION

## 产品规格书

**Date 日期:**

20251103

**Project Name 项目名:**

CMB01010191

**Manufacturer**

**生产制造商**

CM Batteries Co.,Ltd

**Customer ID**

**客户编码:**

SI097

page: 8

### 7. BMS Layout and Diagram BMS 布局和示意图

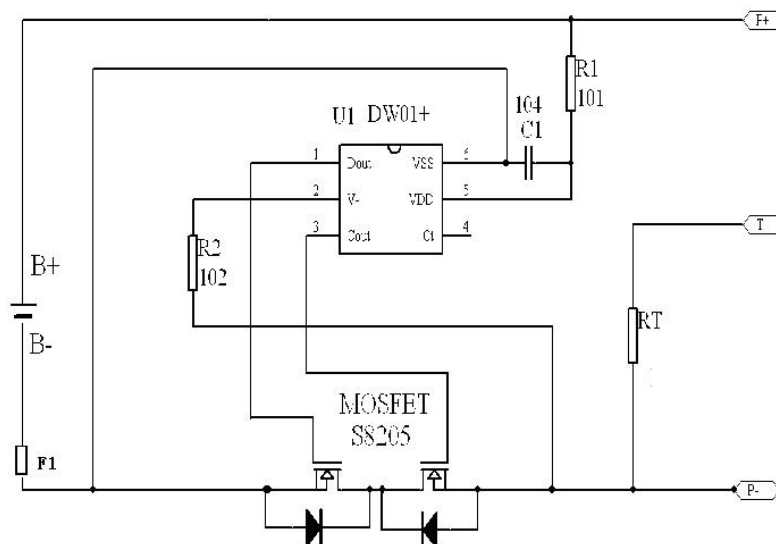

**Tel:** +86 158 1732 3917

**Email:** cherry@cmbatteries.com

**CMB Headquarters:**

Rm.1216 ,  
Baoshan Times Bldg,  
Minqiang Community,  
Minzhi St.,Longhua Dist.,  
Shenzhen  
GuangdongChina

**CMB Facotry:**

Rm.702,7/F,4 BLDG,NO.160,  
Tianxin Luyuan Rd.,  
Keyuan City,Tangxia Town,  
Dongguan,  
Guangdong,China





# PRODUCT SPECIFICATION

## 产品规格书

**Date 日期:**

20251103

**Project Name 项目名:**

CMB01010191

**Manufacturer**

**生产制造商**

CM Batteries Co.,Ltd

**Customer ID**

**客户编码:**

SI097

page: 9

### 8. Material Sheet 材料表

NO. 序号	Item 项目	Description 描述	QTY 数量	Unit 单元	Remark 备注
1	Battery cell 电芯	INR18650 2000mAh	1	PCS	
2	BMS 保护板	/	1	PCS	



**Tel:** +86 158 1732 3917

**Email:** cherry@cmbatteries.com

**CMB Headquarters:**

Rm.1216 ,  
Baoshan Times Bldg,  
Minqiang Community,  
Minzhi St.,Longhua Dist.,  
Shenzhen  
GuangdongChina

**CMB Facotry:**

Rm.702,7/F,4 BLDG,NO.160,  
Tianxin Luyuan Rd.,  
Keyuan City,Tangxia Town,  
Dongguan,  
Guangdong,China

### 9. Battery Pack Reliability Test 电池组可靠性测试

#### 9.1. Testing Condition 测试条件

Each test should be carried out under the standard atmospheric pressure conditions of the test unless otherwise specified.

除非另有规定，否则每次试验应在试验的标准大气压力条件下进行。



# PRODUCT SPECIFICATION

## 产品规格书

**Date 日期:**

20251103

**Project Name 项目名:**

CMB01010191

**Manufacturer****生产制造商**

CM Batteries Co.,Ltd

**Customer ID****客户编码:**

SI097

page: 10



**Tel:** +86 158 1732 3917

**Email:** cherry@cmbatteries.com

**CMB Headquarters:**

Rm.1216 ,  
Baoshan Times Bldg,  
Minqiang Community,  
Minzhi St.,Longhua Dist.,  
Shenzhen  
GuangdongChina

**CMB Facotry:**

Rm.702,7/F,4 BLDG,NO.160,  
Tianxin Luyuan Rd.,  
Keyuan City,Tangxia Town,  
Dongguan,  
Guangdong,China

Temperature 温度 20°C~30°C

Relative Humidity 相对湿度 45%~75%

Atmospheric Pressure 大气压力 86KP~106KP

**Pre-cycle 预循环:**

Do a pre-cycle before the test, charge at 0.2C<sub>5</sub>A at an ambient temperature of 25±5°C, and when the battery terminal reaches the charge limit voltage, put it on hold for 0.5 to 1 hour, and then discharge at 0.2C<sub>5</sub>A to the cut-off voltage.

测试前进行预循环, 在 25±5°C 的环境温度下以 0.2C<sub>5</sub>A 充电, 当电池端子达到充电极限电压时, 将其保持 0.5 至 1 小时, 然后以 0.2C<sub>5</sub>A 放电至截止电压。

**9.2. Requirements for measuring instruments and equipment 测量仪器设备要求**

- The accuracy of the instrument for measuring voltage should not be lower than 0.5, and the internal resistance should not be less than 10KΩ/V.  
测量电压的仪器的精度不应低于大于 0.5 内阻不应小于 10KΩ/V
- The accuracy of the instrument for measuring current shall not be lower than

**0.5 grade.**

电流测量仪器的精度不应低于 0.5 级

- The accuracy of the instrument for measuring time should not be less than± 0.1%.  
仪器测量时间的精度不应低于±0.1%
- The accuracy of the instrument for measuring current shall not be lower than

**0.5 grade.**

电流测量仪器的精度不应低于 0.5 级

- The current of the constant current source is constant and adjustable, and its current variation should be within ±1% during charging or discharging.  
恒流源的电流是恒定和可调的, 在充电或放电过程中其电流变化应在±1%以内
- The voltage of the constant voltage source is adjustable, and its voltage variation range is±0.5%.  
恒压源的电压是可调的, 其电压变化范围为±0.5%
- The accuracy of the dimension measuring instrument shall not be less than 0.02mm.  
尺寸测量仪器的精度不应低于 0.02 毫米
- The sensitivity of the weighing instrument should not be less than 0.1g.  
称重仪器的灵敏度不应低于 0.1g

**9.3. Specifications for testing electrical performance parameters 电气性能参数测试规范**

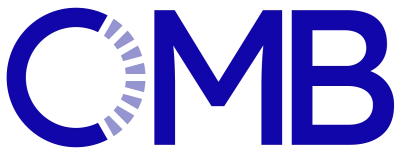

# PRODUCT SPECIFICATION

## 产品规格书

**Date 日期:**

20251103

**Project Name 项目名:**

CMB01010191

**Manufacturer****生产制造商**

CM Batteries Co.,Ltd

**Customer ID****客户编码:**

SI097

page: 11



**Tel:** +86 158 1732 3917

**Email:** cherry@cmbatteries.com

**CMB Headquarters:**

Rm.1216,

Baoshan Times Bldg,

Minqiang Community,

Minzhi St.,Longhua Dist.,

Shenzhen

GuangdongChina

**CMB Facotry:**

Rm.702,7/F,4 BLDG,NO.160,

Tianxin Luyuan Rd.,

Keyuan City,Tangxia Town,

Dongguan,

Guangdong,China

**9.3.1.Charge Test 充电测试****• Test Method 测试方法:****• Standard charging 标准充电:**

charge at  $0.2C_5A$  constant current at  $25\pm 5^\circ C$ , change to constant voltage charging when the power terminal voltage reaches the limit voltage, stop charging until the charging current is less than or equal to  $0.02C_5A$ , and the time does not exceed 8 hours.

在  $25\pm 5^\circ C$  下以  $0.2C_5A$  恒定电流充电, 变为恒定电压当电源端电压达到极限电压时充电, 停止充电直到充电电流小于或等于  $0.02C_5A$ , 并且时间不超过 8 小时。

**• Fast charging 快速充电:**

Charge with a constant current of **1.4 A** at  $25\pm 5^\circ C$ , and change to constant voltage charging when the voltage at the power supply terminal reaches the limit voltage, until the charging current is less than or equal to  $0.02C_5A$ , and the time does not exceed 8 hours, then stop charging.

在  $25\pm 5^\circ C$  下用 **1.4 A** 的恒定电流充电, 并变为恒定当电源端子处的电压达到限制电压, 直到充电电流小于或等于  $0.02C_5A$ , 并且时间不超过 8 小时, 然后停止充电。

**• Approval Standard 合格标准**

Any charging mode can be used, and the charging current can reach a state of less than  $0.02C_5A$  within 8 hours.

可以使用任何充电模式, 充电电流可以达到 8 小时内低于  $0.02C_5A$ 。

**9.3.2. Discharge Test 放电试验****• Test Method 测试方法:****• Standard discharge 标准放电:**

Discharge at a constant current of  $0.2C_5A$  to the discharge cut-off voltage under the condition of  $25\pm 5^\circ C$ ; the discharge time is not less than 5 hours; with  $0.2C_5A$  的恒定电流放电至放电截止电压在  $25\pm 5^\circ C$  的条件下; 放电时间不少于 5 小时

**• Rapid discharge 快速放电:**

Discharge at a constant current of **3A** to the discharge cut-off voltage under the condition of  $25\pm 5^\circ C$ ; the discharge time is not less than **47** minutes.

在  $25\pm 5^\circ C$  的条件下, 以 **3A** 的恒定电流放电至放电截止电压; 放电时间不小于 **47** 分钟。

**• Discharge temperature 放电温度:**

The discharge process can be carried out at  **$-40\sim +85^\circ C$** , without other bad conditions.

放电过程可以在  **$-40\sim +85^\circ C$**  下进行, 没有其他不良条件。

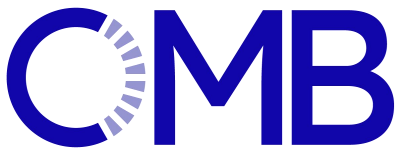

# PRODUCT SPECIFICATION

## 产品规格书

**Date 日期:**

20251103

**Project Name 项目名:**

CMB01010191

**Manufacturer****生产制造商**

CM Batteries Co.,Ltd

**Customer ID****客户编码:**

SI097

page: 12



**Tel:** +86 158 1732 3917

**Email:** cherry@cmbatteries.com

**CMB Headquarters:**

Rm.1216 ,  
Baoshan Times Bldg,  
Minqiang Community,  
Minzhi St.,Longhua Dist.,  
Shenzhen  
GuangdongChina

**CMB Facotry:**

Rm.702,7/F,4 BLDG,NO.160,  
Tianxin Luyuan Rd.,  
Keyuan City,Tangxia Town,  
Dongguan,  
Guangdong,China

**9.3.3. Rated Capacity 额定容量****• Test Method 测试方法:**

At an ambient temperature of  $25\pm 5^{\circ}\text{C}$ , charge the battery according to the method described in Standard charging;

在  $25\pm 5^{\circ}\text{C}$  的环境温度下, 按照“标准充电”中所述的方法对电池进行充电;

After charging, place it at the same temperature of  $25\pm 5^{\circ}\text{C}$  for 1 to 2 hours;  
充电后, 将其置于  $25\pm 5^{\circ}\text{C}$  的相同温度下 1 至 2 小时;

Under the condition of ambient temperature of  $25\pm 5^{\circ}\text{C}$ , discharge the battery according to the method described in Standard discharge.

在环境温度为  $25\pm 5^{\circ}\text{C}$  的条件下, 按照“标准放电”中所述的方法对电池进行放电;

**• Approval Standard 合格标准:**

The standard discharge time is greater than 5 hours, and the rapid discharge time is greater than 47 minutes.

标准放电时间大于 5 小时, 快速放电时间大于 47 分钟。

**9.3.4. Charge Retention 电荷保持能力****• Test Method 测试方法:**

At an ambient temperature of  $25\pm 5^{\circ}\text{C}$ , charge the battery according to the method described in Standard charging;

在  $25\pm 5^{\circ}\text{C}$  的环境温度下, 按照“标准充电”中所述的方法对电池进行充电;

Under the same ambient temperature of  $25\pm 5^{\circ}\text{C}$ , the battery should be stored for 30 days in an open circuit state;

在  $25\pm 5^{\circ}\text{C}$  的相同环境温度下, 电池应在开路状态下储存 30 天;

Under Under the same ambient temperature of  $25\pm 5^{\circ}\text{C}$ , perform a standard discharge operation on the battery.

在环境温度为  $25\pm 5^{\circ}\text{C}$  的条件下, 按照“标准放电”中所述的方法对电池进行放电。

**• Approval Standard 合格标准:**

Standard discharge time > 4.0 hours; no other failure conditions during discharge

标准放电时间 > 4.0 小时; 期间无其他故障情况。

**9.3.5. Internal Impedance 内阻****• Test Method 测试方法:**

At an ambient temperature of  $25\pm 5^{\circ}\text{C}$ , use a dedicated battery comprehensive tester to measure the internal resistance between the positive and negative electrodes at the battery interface. The measurement should not be less than 5 times, and the corresponding valid results should be averaged.

在  $25\pm 5^{\circ}\text{C}$  的环境温度下, 使用专用的电池内阻测试仪测量电池的正极和负极之间的内阻。测量次数不应小于 5 次, 对有效测量结果计算平均值。

**• Approval Standard 合格标准:**

Internal Impedance(内部阻抗) < 100mΩ

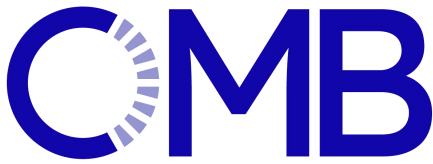

# PRODUCT SPECIFICATION

## 产品规格书

**Date 日期:**

20251103

**Project Name 项目名:**

CMB01010191

**Manufacturer****生产制造商**

CM Batteries Co.,Ltd

**Customer ID****客户编码:**

S1097

page: 13



**Tel:** +86 158 1732 3917

**Email:** cherry@cmbatteries.com

**CMB Headquarters:**

Rm.1216 ,  
Baoshan Times Bldg,  
Minqiang Community,  
Minzhi St.,Longhua Dist.,  
Shenzhen  
GuangdongChina

**CMB Facotry:**

Rm.702,7/F,4 BLDG,NO.160,  
Tianxin Luyuan Rd.,  
Keyuan City,Tangxia Town,  
Dongguan,  
Guangdong,China

**9.3.6. Life Cycle Test 循环寿命测试****• Test Method 测试方法:**

The whole process of this test should be carried out at an ambient temperature of  $25\pm 5^{\circ}\text{C}$ ;

本试验的整个过程应在  $25\pm 5^{\circ}\text{C}$  的环境温度下进行

The cycle process includes two actions of charging and discharging, the cycle starts as charging, and the cycle ends as discharging;

循环过程包括充电和放电两个动作, 循环以充电开始, 以放电结束;

Charge with  $0.2C_5\text{A}$  constant current, change to constant voltage charging when the battery terminal voltage reaches the charging limit voltage, and stop

charging when the charging current is less than or equal to  $0.02C_5\text{A}$ ;

以  $0.2C_5\text{A}$  电流恒流充电, 但达到充电限制电压时, 改为恒压充电; 当充电电流小于或等于  $0.02C_5\text{A}$  时停止充电;

After leaving it aside for 0.5 hours to 1 hour, discharge it with a constant current of  $0.2 C_5\text{A}$ . When the terminal voltage of the battery reaches the cut-off voltage,the discharge ends;

将其放置 0.5 至 1 小时后, 以  $0.2 C_5\text{A}$  电流恒流放电。当电池的电压达到截止电压时, 放电结束;

After resting for 0.5 hours to 1 hour, enter the next charge and discharge cycle action.

放置 0.5 小时至 1 小时后, 进入下一次充电和放电循环行动。

**• Approval Standard 合格标准:**

Cycle Life **350** times, remaining capacity  $\geq 70\%$  of initial capacity

循环寿命 **350** 次, 剩余容量  $\geq$  初始容量的 **70%**。

**9.4. Environmental Performance 环境性能****9.4.1. High Temperature Performance 高温性能****• Test Method 测试方法:**

After the standard  $0.2C_5\text{A}$  charge is completed at an ambient temperature of  $25\pm 5^{\circ}\text{C}$ , put the battery in a high-temperature box at  $(+85\pm 2)^{\circ}\text{C}$  and keep the temperature constant for 4 hours; discharge at a constant current of  $0.2\text{A}$  to the discharge cut-off voltage, and the discharge ends.

在环境温度为  $25\pm 5^{\circ}\text{C}$  的情况下, 以  $0.2C_5\text{A}$  电流标准充电结束后, 将电池放在  $(+85\pm 2)^{\circ}\text{C}$  的高温箱中, 并保持温度不变 4 小时。再以  $0.2C_5\text{A}$  的恒定电流放电至放电截止电压, 放电结束。

After the end of the test, place it for 2 hours under the condition of  $25\pm 5^{\circ}\text{C}$ , then make an appearance inspection.

试验结束后, 在  $25\pm 5^{\circ}\text{C}$  的情况下放置 2 小时, 然后进行外观检查。

Under an ambient temperature of  $25\pm 5^{\circ}\text{C}$ , perform a standard discharge operation on the battery.

在环境温度为  $25\pm 5^{\circ}\text{C}$  的情况下, 对电池进行标准放电操作。

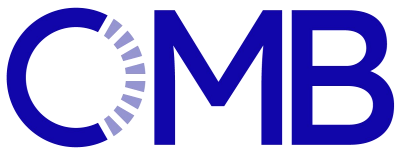

# PRODUCT SPECIFICATION

## 产品规格书

**Date 日期:**

20251103

**Project Name 项目名:**

CMB01010191

**Manufacturer****生产制造商**

CM Batteries Co.,Ltd

**Customer ID****客户编码:**

SI097

page: 14



Tel: +86 158 1732 3917

Email:cherry@cmbatteries.com

**CMB Headquarters:**

Rm.1216 ,  
Baoshan Times Bldg,  
Minqiang Community,  
Minzhi St.,Longhua Dist.,  
Shenzhen  
GuangdongChina

**CMB Factory:**

Rm.702,7/F,4 BLDG,NO.160,  
Tianxin Luyuan Rd.,  
Keyuan City,Tangxia Town,  
Dongguan,  
Guangdong,China

**Approval Standard 合格标准:**

the discharge capacity is not less than the minimum capacity of the product;  
the battery has no deformation, leakage, smoke or fire.

电池的放电容量不低于产品的最小容量; 电池没有变形、漏液、冒烟或起火。

**9.4.2. Low Temperature Performance 低温性能****Test Method 测试方法:**

After the standard 0.2C<sub>5</sub>A charging is completed at an ambient temperature of 25±5°C, put the battery in a low-temperature box at (-40±2)°C for 16 to 24 hours discharge it at a constant current of 0.2C<sub>5</sub>A to 2.4 V, and the discharge ends.

在环境温度为 25±5°C 的情况下完成标准的 0.2C<sub>5</sub>A 充电后, 将电池放在(-40±2)°C 的低温箱中 16 至 24 小时, 以 0.2C<sub>5</sub>A 的恒定电流放电至 2.4 V, 然后放电结束。

After the end of the test, place it for 2 hours under the condition of 25±5°C, then make an appearance inspection.

试验结束后, 在 25±5°C 的条件下放置 2 小时, 然后进行外观检查。

**Approval Standard 合格标准:**

The battery is at -40±2 °C, and the discharge capacity is not less than 50%\* nominal capacity; the battery has no deformation, leakage, smoke or fire.

电池处于-40±2 °C, 放电容量不低于 50% \*标称容量; 电池没有变形、泄漏、冒烟或起火。

**9.4.3. Constant Temperature and Humidity Performance 恒温恒湿性能****Test Method 测试方法:**

After the standard 0.2C<sub>5</sub>A charging at an ambient temperature of 25±5°C, put the battery in a constant temperature and humidity box at 40°C and 95%RH for 48 hours, and then restore it for 2 hours at an ambient temperature of 25±5°C; use a constant current of 0.2C<sub>5</sub>A Discharge to 2.4 V, the discharge ends;

在环境温度为 25±5°C 的情况下进行标准的 0.2C<sub>5</sub>A 充电后, 将电池放在 40°C 和 95%RH 的恒温恒湿箱中 48 小时, 然后在环境温度为 25±5°C 的情况下搁置 2 小时; 再使用 0.2C<sub>5</sub>A 的恒定电流放电至 2.4 V, 放电结束;

After the end of the test, place it for 2 hours under the condition of 25±5°C, then make an appearance inspection.

试验结束后, 在 25±5°C 的条件下放置 2 小时, 然后进行外观检查。

**Approval Standard 合格标准:**

There should be no obvious deformation, rust, smoke or explosion on the appearance of the battery. Discharge at 0.2C<sub>5</sub>A, discharge capacity 60%\* nominal capacity.

电池的外观不应有明显的变形、生锈、冒烟或爆炸等现象。电池的外观不应有明显的变形、生锈冒烟或爆炸。在 0.2C<sub>5</sub>A 时放电, 放电容量为 60%\*标称容量。



# PRODUCT SPECIFICATION

## 产品规格书

**Date 日期:**

20251103

**Project Name 项目名:**

CMB01010191

**Manufacturer****生产制造商**

CM Batteries Co.,Ltd

**Customer ID****客户编码:**

SI097

page: 15

**Tel:** +86 158 1732 3917**Email:** cherry@cmbatteries.com**CMB Headquarters:**

Rm.1216,  
Baoshan Times Bldg,  
Minqiang Community,  
Minzhi St.,Longhua Dist.,  
Shenzhen  
GuangdongChina

**CMB Facotry:**

Rm.702,7/F,4 BLDG,NO.160,  
Tianxin Luyuan Rd.,  
Keyuan City,Tangxia Town,  
Dongguan,  
Guangdong,China

**9.4.4. Heat Test 热冲击**

## • Test Method 测试方法:

After standard 0.2C<sub>5</sub>A charging at ambient temperature of 25±5°C;在环境温度为 25±5°C 的情况下进行标准的 0.2C<sub>5</sub>A 充电;

Put the sample into the hot box, raise the temperature to 130°C±2°C at a rate of (5°C±2°C)/min and keep it warm for 30min;

将样品放入恒温箱, 以(5°C±2°C)/分钟的速度升温至 130°C±2°C, 保温 30 分钟;

## • Approval Standard 合格标准:

No fire, no explosion.

不起火, 不爆炸。

**9.4.5.Vibration Test 振动测试**

## • Test Method 测试方法:

at an ambient temperature of 25±5°C, 0.2C<sub>5</sub>A charging at ambient temperature with GB40165-2021 standard and the parameters of Sine Vibration Test:在环境温度为 25±5°C 的情况下, 以标准 0.2C<sub>5</sub>A 充满电后, 按 GB40165-2021 标准, 按下表参数进行正弦振动测试。

频率		振动参数	对数扫频循环时间 (7Hz~200Hz~7Hz)	轴向	震动周期数
起始	至				
f <sub>1</sub> =7Hz	f <sub>2</sub>	a <sub>1</sub> =1 gn	15min	X	12
f <sub>2</sub>	f <sub>3</sub>	S=0.8mm		Y	12
f <sub>3</sub>	f <sub>4</sub> =200Hz	a <sub>2</sub> =2 gn		Z	12
返回至 f <sub>1</sub> =7Hz				总计	36

f<sub>1</sub>, f<sub>4</sub>-----下限, 上限频率;  
F<sub>2</sub>, f<sub>3</sub>-----胶越点频率 (f<sub>2</sub>≈17.62Hz, f<sub>3</sub>≈49.84Hz);  
a<sub>1</sub>, a<sub>2</sub>-----加速度值;  
S-----位移幅度;  
g<sub>n</sub>-----重力加速度, 在环境试验中圆整取值为 10m/s<sup>2</sup>

振动参数是指位移或加速度的最大绝对值, 例如: 位移幅值为 0.8mm 对应的峰值--峰值的位移幅值为 1.6mm

## • Approval Standard 合格标准:

No fire, no explosion, no leakage.

不起火, 不爆炸, 无漏液。

**9.5. Battery Safety Protection Performance Test Range 电池安全保护性能测试范围****9.5.1.Overcharge Protection 过度充电保护**

## • Test Method 测试方法:

at an ambient temperature of 25±5°C, 0.2C<sub>5</sub>A charging at ambient temperature; 在环境温度 25±5°C 下, 以 0.2C<sub>5</sub>A 标准充电方式充满电;2C<sub>5</sub>A current, 2 times the standard voltage charging for 8 hours, and then proceed as follows:以 2C<sub>5</sub>A 电流, 2 倍标准电压, 充电 8 小时, 然后按以下步骤进行:

Standard discharge to termination voltage;标准放电至终止电压

Standard charge to limit voltage;标准充电至截止电压



# PRODUCT SPECIFICATION

## 产品规格书

**Date 日期:**

20251103

**Project Name 项目名:**

CMB01010191

**Manufacturer****生产制造商**

CM Batteries Co.,Ltd

**Customer ID****客户编码:**

SI097

page: 16



**Tel:** +86 158 1732 3917

**Email:** cherry@cmbatteries.com

**CMB Headquarters:**

Rm.1216 ,

Baoshan Times Bldg,

Minqiang Community,

Minzhi St.,Longhua Dist.,

Shenzhen

GuangdongChina

**CMB Facotry:**

Rm.702,7/F,4 BLDG,NO.160,

Tianxin Luyuan Rd.,

Keyuan City,Tangxia Town,

Dongguan,

Guangdong,China

Standard discharge to termination voltage;标准放电至终止电压

- Approval Standard 合格标准:

No fire, no explosion. Battery voltage < overcharge protection voltage.

不起火, 不爆炸。电池电压<过充电保护电压。

**9.5.2. Over discharge Test 过度放电测试**

- Test Method 测试方法:

After the standard 0.2C<sub>5</sub>A charging at ambie

Under the condition of ambient temperature 25±5°C,the battery is discharged

To the cut-off voltage at 0.2C<sub>5</sub>A and connected to an external (30×1) Ω load

for 24hours. Then proceed as follows:

在环境温度为 25±5°C 的条件下, 在 0.2C<sub>5</sub>A 的条件下将电池放电到截止电压, 并与外部 (30×1)Ω负载连接 24 小时。然后进行如下操作:

Standard charge to limit voltage;标准充电至截止电压

Standard discharge to termination voltage;标准放电至终止电压

at an ambient temperature of 25±5°C,, discharge at 0.01 C<sub>5</sub>A until the discharg

e

current is 0A

在 25±5°C 环境温度下, 以 0.01 C<sub>5</sub>A 放电, 直到放电电流为 0A。

The battery should not explode, catch fire, smoke or leak.

电池不应爆炸、起火、冒烟或泄漏。

**9.5.3. External Short-circuit Test 外部短路测试**

- Test Method 测试方法:

After charging at 0.2C<sub>5</sub>A at at an ambient temperature of 25±5°C;

short-circuit the positive and negative poles with a 0.1Ω resistor for 1.5 hours;

after the short circuit is disconnected, charge for 10 seconds with a current

of 0.2C<sub>5</sub>A,and then measure the battery voltage.

在 25±5°C 环境温度下以 0.2C<sub>5</sub>A 充满电后, 用 0.1Ω的电阻将正负极短路 1.5 小时。短路断开后, 以 0.2C<sub>5</sub>A 的电流充电 10 秒, 然后测量电池电压。

- Approval Standard 合格标准:

Battery voltage discharge cut-off voltage; the battery should not explode, fire, smoke or leak.

电池电压≥放电截止电压;电池应不爆炸, 不起火, 不冒烟或漏液。

**10. Transportation, Storage 运输、存储****10.1. Transportation 运输**

The battery should be packed into a box for transportation at a 30% load.

During the transportation, it should prevent severe vibration, impact or

squeeze, prevent sun and rain, and adapt to the transportation of sea, land and air.

电池应按 30%的带电量装入箱内运输。在运输过程中, 应防止剧烈振动、撞击或挤压, 防止日晒雨淋, 适应海、陆、空的运输。



# PRODUCT SPECIFICATION

## 产品规格书

**Date 日期:**

20251103

**Project Name 项目名:**

CMB01010191

**Manufacturer****生产制造商**

CM Batteries Co.,Ltd

**Customer ID****客户编码:**

SI097

page: 17



**Tel:** +86 158 1732 3917

**Email:** cherry@cmbatteries.com

**CMB Headquarters:**

Rm.1216 ,  
Baoshan Times Bldg,  
Minqiang Community,  
Minzhi St.,Longhua Dist.,  
Shenzhen  
GuangdongChina

**CMB Facotry:**

Rm.702,7/F,4 BLDG,NO.160,  
Tianxin Luyuan Rd.,  
Keyuan City,Tangxia Town,  
Dongguan,  
Guangdong,China

**10.2. Storage 存储**

The battery should be stored in a clean and dry and ventilated room with a ambient temperature of  $-20^{\circ}\text{C}$  to  $+25^{\circ}\text{C}$ . It should avoid contact with corrosive substances and stay away from the fire source and thermal source.

电池应存放在清洁、干燥、通风的室内，环境温度为  $-20^{\circ}\text{C}$ 至  $+25^{\circ}\text{C}$ 。应避免接触腐蚀性物质，并远离火源和热源。

**11.Handling Instructions 操作说明**

Read the following precautions carefully to ensure the correct use of lithium ion batteries.CM BATTERIES is not responsible for any problems arising from the following precautions.

仔细阅读以下预防措施，以确保正确使用锂离子电池。CM BATTERIES 不负责任何引起的任何问题负责。

**Danger! 危险!**

- Do not put the battery into the water or wet it!  
请勿将电池放入水中或将其弄湿!
- It is forbidden to charge the battery under the source of fire or extremely heat!  
Do not use or store batteries near the heat source (such as fire or heater)! If the battery leaks or produces a odor, it should be immediately removed from the open flame;  
严禁在火源或极热的情况下给电池充电! 不要在热源 (如火或加热器) 附近使用或储存电池! 如果电池发生泄漏或产生异味, 应立即将其从明火上移开。
- Do not use any chargers other than those recommended!  
请不要使用推荐以外的任何充电器!
- Do not reverse the positive (+) and negative (-) terminals.  
不要把电池的正(+)和负(-)接反。
- Do not put the battery into the fire or heat it to the battery!  
不要把电池放入火中或加热电池!
- Do not short-circuit the battery by connecting wires or other metal objects to the positive (+) and negative (-) terminals.  
不要用电线或其他金属物体短接电池的正极 (+) 和负极 (-) , 使电池短路。
- Do not pierce the battery casing with a nail or other sharp object, break it open with a hammer, or step on it.  
不要用钉子或其他尖锐物体刺穿电池外壳, 不要用锤子砸开电池外壳, 也不要踩在上面。
- Do not strike,throw or subject the battery to sever physical shock.  
请勿敲击、投掷或使电池受到严重的物理冲击。
- Do not directly solder the battery terminals.  
不要直接焊接电池端子。
- Do not attempt to disassemble or modify the battery in any way.  
不要试图以任何方式拆卸或修改电池。
- Do not place the battery in a microwave oven or pressurized container.  
不要把电池放在微波炉或加压的容器中。

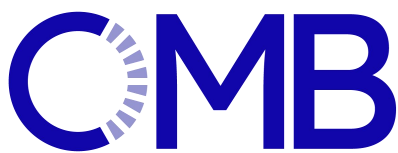

# PRODUCT SPECIFICATION

## 产品规格书

**Date 日期:**

20251103

**Project Name 项目名:**

CMB01010191

**Manufacturer****生产制造商**

CM Batteries Co.,Ltd

Customer ID

**客户编码:**

SI097

page: 18



**Tel:** +86 158 1732 3917

**Email:** cherry@cmbatteries.com

**CMB Headquarters:**

Rm.1216,

Baoshan Times Bldg,

Minqiang Community,

Minzhi St.,Longhua Dist.,

Shenzhen

GuangdongChina

**CMB Factory:**

Rm.702,7/F,4 BLDG,NO.160,

Tianxin Luyuan Rd.,

Keyuan City,Tangxia Town,

Dongguan,

Guangdong,China

- Do not use the battery in combination with primary batteries (such as dry-cell batteries) or batteries of different Capacity type or brand.

请勿将电池与原电池（如干电池）或不同容量类型或品牌的电池一起使用。

- Do not use the battery if it gives off an odor, generates heat, becomes discolored or deformed, or appears abnormal in any way. If the battery is in use or being recharged, remove it from the device or charger immediately and discontinue use.

如果电池发出异味，产生热量，变色或变形，或出现任何异常，请不要使用。如果电池正在使用或正在充电，请立即将其从设备或充电器中取出，并停止使用。

**Caution! 注意事项!**

Do not use or store the battery where is exposed to extremely hot, such as under window of a car indirect sunlight in a hot day. Otherwise, the battery may be overheated. This can also reduce battery performance and/or shorten cycle life.

If the electrolyte enters the eyes after the battery leaks, do not wipe it, apply water to rinse, and immediately seek medical assistance. If you do not deal with it in time, your eyes will be harmed.

The battery can only be used under the following conditions, otherwise it will reduce the performance of the battery or shorten the service life of the battery.

不要在极热的地方使用或存放电池。例如高温天气下，搁置在阳光直射的汽车窗下。否则，电池可能会过热。这也会降低电池性能和/或缩短循环寿命。

如果电池泄漏后，电解液进入眼睛，不要擦拭，用清水冲洗，并立即寻求医疗援助。如果不及时处理，眼睛会受到伤害。

电池只能在以下条件下使用，否则会降低电池的性能或缩短电池的使用寿命。

**Operating Environment 工作环境:**

**Charge 充电:** -20 ° C~+60 ° C

**Discharge 放电:** -40° C~+85° C

**Storage for 30 days 储存 30 天:** -20 ° C~+45 ° C

**Storage for 90 days 储存大于 90 天:** -20 ° C~+25 ° C

**12. Amendment of this Specification 产品规格书的修订**

This specification is subject to change with prior notice.

本公司有权对本产品规格书进行修订。